THE "LIGHT SHAFT"

January/February 2024



A 2023 Pub Crawl photo opportunity, of all
the cars and humans.

AUSTIN 7 CLUB INC. Reg No. A0003290N
P.O. BOX 462
MOORABBIN VIC 3189
austin7club.org



Facebook <http://www.facebook.com/Austin-7-Club-Inc-1544252182541126/>



Photo of Club members enjoying the Lambley Gardens on the Pub Crawl.

Photo Russell Dickson
See Past Event on Page 24.



With the Pub Crawl Dinner, held in the Garden Room at Buda, the theme was "Garden".

Photos Bev Logan





Magazine of the Austin 7 Club Inc. In its 75th year

Foundation Patron of the Club

Col. A C R Waite,(dec.) MC, OStJ, DL, JP, Freeman of the

**City of London 1894—1991., Life member of the British Racing Drivers Club.
Winner of the first Australian Grand Prix.**

CALENDAR OF EVENTS

FEBRUARY

3	Sat	7	A	Tool Up at Austin 7 Heaven
3	Sat			Berwick Swap Meet
6	Tues			MA State Council - Delegates Mtg
7	Wed	7	A	M.G.M./Spares
10	Sat	7		Spares/B.B.Q
10	Sat			Federation Delegates Mtg at Maryborough HVC
11	Sun			Picnic at Hanging Rock Classic Car Show
16	Fri	7		Tool Up at Austin 7 Heaven
16-18	Fri-Sun			Begonia Rally "Blooming Gold" VCCC Ballarat
17	Sat			Club hire – Janne's All Day Craft Day
18	Sun		A	AOMC British & European Show
19	Mon			AOMC Delegates Meeting
21	Wed	7	A	H.A.S./Spares
24	Sat			Wandin Draught Horse & Yesteryear Festival
23-25	Fri-Sun			World Superbikes – Phillip Island Grand Prix Circuit
25	Sun	7	A	Progressive Lunch

Club Calendar Information

- A** Event counts towards the 750 Shield and Frank Walter Trophy
- S** Event counts towards the Sprint – Hillclimb and Doc Grosvenor trophies
- 7** An event conducted by the Austin 7 Club

Spares Hours Saturday - 12:00 Noon to 2:30pm

Spares Hours for MGM. - 7:30pm to 8:00pm sharp

Spares Hours for Hot Air Session. - 7:30pm to 9:00pm sharp

MARCH

2	Sat	7		Tool Up at Austin 7 Heaven
2-3	Sat-Sun		S	Rob Roy Revival
6	Wed	7	A	M.G.M./Spares
7-10				Phillip Island Classic Festival of Motorsport
7-11	Thur-Mon		A	Austins Over Australia 2024
9	Sat	7		Spares/B.B.Q.
10	Sun			Yarra Glen Swap Meet - VDC
7-10	Thur-Sun			VHRR Phillip Island Classic Festival of Motorsport
11	Mon			Labour Day
15	Fri	7		Tool Up at Austin 7 Heaven
20	Wed	7	A	H.A.S./Spares
21-24	Thurs-Sun			Australian Grand Prix
24	Sun			Mortlake Picnic - Federation
23	Sat		S	Eddington Sprints
24	Sun			Kalorama Rally
27	Wed	7	A	URRRS - Synchrotron
29	Fri			Good Friday
29	Fri		A	Hot Cross Bun Picnic Run – Braeside Park
30	Sat			First Day of Autumn School Holidays
30-31	Sat/Sun			Wunghnu Picnic - Federation

APRIL

1	Mon			Easter Monday
3	Wed	7	A	M.G.M./Spares
5	Fri	7		Tool Up at Austin 7 Heaven
6	Sat	7		Spares/BBQ
6	Sat			OST Scrutineering - Lilydale
7	Sun	7	A	Learn to Drive Day

COMING

You can see a regularly updated 2024 Club Calendar on our website

Many dates are still tentative, or not confirmed

(Tentative Events/Dates are in Italics)

**THE AUSTIN 7 CLUB ROOMS AND CLUB SPARES
are located at
UNIT 8/9, 19-23, KYLIE PLACE, CHELTENHAM NORTH.**

All correspondence to the Secretary:

Austin 7 Club Inc. P O Box 462, Moorabbin. Vic 3189

Please do not send mail to the clubrooms

Spares are open:-

M.G.M. from 7.30 p.m. to 8.00 p.m. sharp

H.A.S. from 7.30 p.m. to 9.00 p.m. and between 12:00 p.m. and 2:30 p.m. on the Saturday following the M.G.M. (or the following Saturday if the former clashes with a Club Event)

Spares can be ordered by mail from:

Janne and Robert Humphreys, 27 Peters Drive, Cheltenham Vic 3192

Or mailorderparts@austin7club.org

DISCLAIMER

The Austin 7 Club Inc. (A7C), its Officers and the Committee will not be held liable for any errors and/or omissions in items that are published in The Light Shaft in good faith. Publication of an advertisement, or expression of views in articles and reports, does not necessarily imply endorsement by the A7C.

PLEASE PAY YOUR MEMBERSHIP RENEWAL ASAP

Your renewal Notice was attached to the December Lightshaft

***If you did not keep it, please contact the Membership
Secretary, Russell Dickson***

LIGHTSHAFT COPY CLOSING

Copy for Lightshaft **closes** late on

Saturday 17 February 2024.

PRESIDENT'S REPORT

Welcome to 2024. This year the club will continue to evolve as we meet the challenges of the ever-changing world. There is mandatory reporting required by government departments, taxation reporting, insurance issues and motor sport governance. All of these issues are attended to by the committee members.

All other matters such as rallies, day runs, social outings, OSTs etc., are the domain of the members, and supported by the committee. As the saying goes, you only get out of a club, what you put in. That being the case, as president I request that as much as possible you support your club by attending events.

If you have an idea for an outing or a competition event, please advise the committee for their support.

The Light Shaft is your communication tool with the club; please submit articles on events you have attended, or parts for sale, or parts you may wish to purchase. Technical articles or general comments are most welcome.

Trust you enjoy 2024 and we look forward to seeing you.

Len Kerwood 0419 504 233

MEMBERSHIP REMINDER - SUBSCRIPTIONS

Subscriptions were due for payment before 31 December 2023.

If you have not paid your membership you are now UNFINANCIAL.

Notice is hereby given that all members who have not paid their outstanding subscriptions by the last day in February will cease to be members and will be removed from the Membership Register.

Should they later wish to join as Full or Associate Members they will be required to join the club and pay the **joining fee in addition to the annual subscription.**

Please consider this as a notice in writing as prescribed in Club Rule 6.10.

MEMBERSHIP REPORT

Thank you to all members who have renewed their membership for 2024. There are now just over 300 members who are current for this year but still over 100 who have not paid as yet.

If you are unfinancial, the March Light Shaft will be the last one you receive and a \$35 joining fee will apply if you rejoin after the end of February.

We are pleased to welcome the following new members:

Gordon Love from Monavale, NSW has a 1936 Ruby.

Gordon Dobie of Moorabbin is renewing some old acquaintances, having previously been a member in 1959 and the early '60s when he was involved with the racing fraternity. It was nice to meet Gordon at the Plum Pudding Night.

William Power is also rejoining having last been a member in 2010 but now residing in Campbelltown, TAS. He has a 1928 Chummy.

Another rejoining member is John Liston from Stoneleigh who was last a member in 1999. He also has a 1936 Ruby.

From Andover, Hampshire in the United Kingdom we welcome Ralph Stratton.

We would also like to have Steven Bennett as a new member but we don't know anything about him apart from receiving a payment via EFT for a membership and joining fee. If anyone knows Steven could they please ask him to get in touch so that his membership can be processed.

Russell

A truck loaded with Vix Vaporub overturned on the highway.

Amazingly, there was no congestion for 12 hours.

Vale - Bob Riches

More recently Bob was a member of the Austin 7 Club of NSW, but, prior to moving interstate, he was an early member of our Club. Bob was a good mate of Doug Veel.

He joined our Club as member no. 177, about June 1952.

Committee 3 times, as Interstate Secretary from 1954 to 1956, and was active, during those years, in continuing to encourage the establishment of Austin 7 Clubs in SA, NSW, Qld and WA, and he also was very active as a motor sport administrator, serving as a speed event steward at numerous meetings, a number of those at Fishermans Bend.

Won Aggregate Cup for 1953.

LS records 1953 2nd in Treasure Hunt, followed by a June 1953 2nd in the Mountain Trial, a July 1953 1st in Navigators Night Trial, followed by an August 1953 2nd Park Orchards (the Grosvenor Ulster won). Then in October 1953 1st Touring Car at Club Hillclimb at Upper

Beaconsfield, in his standard 1933 roadster. He continued to be a fierce competitor in Victoria, before moving interstate.

Members may recall that he was a the Centenary National Austin 7 Rally, in Warnambool, shortly after selling his modified replica Austin 7 Ulster.

Seen here with Judith.



Vale - Graham Fossey

Graham was a member of the Austin 7 Club from 2018-2022. He joined after purchasing the ex-Howard plastic Ulster. Graham would have been a member of a number of clubs including the Veteran Car Club and the VSCC over many years.

As well as the Austin 7 he had a veteran Tweeny cyclecar and, I think, a Hupmobile. He is included with a car in at least one of the James Flood books.

Russell

Vale - David Linke

I observe, from a notice in the A30 magazine, that David has died recently. He was a regular attendee at our Club, during the years that he was a member. I do not recall what Austin/s he may have owned, or how recently his membership lapsed.

Editor's Wafflings - New Members

It seems that often a “new” member is actually a recycled member, from the past.

Gordon Dobie, who recently “joined” the Club, is an example.

Gordon first joined in 1962, as member No 834, back in the early days when our member numbers were sequential, starting from 1 in 1950, and continuing until the mid-1970s.

Graham Dobie was member 833, and Keith Dobie was member 930.

MEMBERSHIP REMINDER - SUBSCRIPTIONS

IS YOUR CLUB PERMIT VALID ?

Subscriptions are due for payment before 31 December.

If you have not paid your membership by 31 December you will be UNFINANCIAL in 2024.

Your Club Permit is subject to the condition:-

“ the permit holder must remain a financial member of an approved club”

If you fail to pay your membership before 31 December there are a number of risks:-

- Your permit will be invalid
- It is possible that you may need to re-apply for a Permit, with the attendant cost of Roadworthy etc.
- The Club Permit Officer will be required to report your unfinancial status to VicRoads
- The Austin 7 Club's authorization under the Scheme could be at risk

The Club Permit Scheme may be at risk.

Club Permit Officer

Letter to Editor

In the December Lightshaft, Bill Sheehan made comments about the photo that had appeared on the back cover of the November edition, and clearly identified that the photo was most likely after 1926.

The incorrect caption said:-

“1925 An Austin Seven was on hand to greet Bert Hinkler when he reached Canberra on a leg of one of his many famous record-breaking flights.”

So! I gave the challenge:-

What is the aircraft? Who are the people? Where is it?

Len Kerwood responded and sent three photos, one with a story attached, as follows.

I have now established that the photo was on 14th of March 1928 when Bert received the 2000 pound cheque in Canberra.

Bert Hinkler visits Canberra after his record-breaking flight on February 7th 1928 (15 days) In March he then flew to the York Park Canberra to collect the 2000 pound cheque from Prime Minister Bruce. The last photo shows the plane with the wings folded at Canberra. Please note the last note says that you can copy this photo or print for Training or Research and study other wise you need permission from National Archives of Australia. In the light shaft photo, Bert Hinkler must be the man behind the propeller as per the first photo. You will also note the same fence and terrain in both the Light-shaft photo and this photo.

Cheers

Len

Letter to Editor

The aircraft was an Avro Avian, an experimental aircraft with which Hinkler had considerable experience. He had flown the aircraft in several air races in 1926-27; however the aircraft was significantly modified over the period. On February 7 1928, flying solo, he took off from Croydon, England and reached Darwin, Australia on February 22, 1928. Record after record had been shattered by G-EBOV, this amazing light aircraft.



Both the original aircraft, G-EACQ and G-EBOV are on display at the Queensland Museum in Brisbane, Australia.

Editor's Note

My guess, to part of the unanswered questions, is that one other in the photo was Stanley Melbourne Bruce, Prime Minister, MP for Flinders.

COMING EVENTS

To all of you who have a car under the Club Permit Scheme.

Check your date of EXPIRY of your Permit.

ALSO check ALL details - including expiry date, addresses etc.

When paying ALWAYS retain your receipt.

Keep a scanned copy of your receipt with your logbook.

Please get a My VicRoads Account.

A My VicRoads Account also assures you of an email reminder for renewal of all your car registrations, permits and Drivers Licence.

Check your My VicRoads Account to ensure that your CPS cars appear - you may need to take some additional action, for this to happen, but it is worthwhile

SPARES

*PLEASE come to Spares **with a list prepared beforehand**, to speed up being served, and make it easier on our volunteers.*

***PLEASE** When you visit Spares try to make all your purchases in **a single transaction**.*

This makes the book-work much easier for our volunteers, and respects other members who also want to make purchases.

EVENTS FOR YOUR AUSTIN 7 IN 2024

If you have an idea for an event for our Austin 7s, or if you want to help run an event, but need help, let a Committee member know, and it can become part of the Club Calendar for 2024.

Perhaps you could even revive, or recreate, a form of event that was popular in the past but lacked an active organiser.

COMING EVENTS

Tool Up at Austin 7 Heaven - SATURDAY 3 February 2024

A *new format* just for SATURDAY Tool UP. Come in whatever part of the day suits you. Sandwich and drink refreshment will be available all day

Monthly General Meeting Wednesday 7 February 2024

Our first General Meeting for 2024, I know you will all be excited to tell everyone where you took your Austin 7 for Christmas, or New Year.

Have you planned a rejuvenation for your Austin 7?

Come and collect the parts, so that you'll be able to lose them before you get around to doing the work.

Spares / BBQ Saturday 10 February 2024

Browse the Spares, buy a few, then ask a knowledgeable member how to fit it whilst munching a snag. A great time to share stories.

Tool Up at Austin 7 Heaven - Friday 16 February 2024

These FRIDAY Tool Up days remain as usual, with a BBQ Lunch.

What project do you need help with, or some machining?

Or perhaps the ultimate - Do It Yourself.

BUT, still far, far better, are the facilities, and many knowledgeable helpers at Austin 7 Heaven.

Tool Up: “to provide someone or something with the tools or equipment needed for making something, or to be provided with these tools or equipment.”

Over 100 years ago two brothers announced that they could fly.

Turns out, they were Wright.

COMING EVENTS

JANNE'S SCRAPBOOKING DAY—Saturday 17 February 2024

I have opened the booking for - *SUMMER FUN*

There will be a card making session from 1.30 to 3.30 in the afternoon where you will be making 6 cards. The cost for this workshop is \$15.00.

The cost of just attending the all day scrapbooking session is \$40 and if you wish to do both sessions the cost is \$50.00.

I require payment when you book to come. and I can give you my bank account details when you contact me so you can pay me directly.

Please contact me as follows:

Email: janne.humphreys@yahoo.com.au

Mob: 0427 772 261

Phone: (03) 9583 6316

TRAINING DAY - Saturday 17 February .2024

CANCELLED

THE VICTORIAN CLUB PERMIT SCHEME

*It is the policy of our Club that owners of Austin 7 Club Club Permit vehicles **MUST maintain financial membership at all times.***

Your Club Permit Officers are, our Membership Secretary Russell Dickson and Robert Humphreys.

Remember to plan ahead if you need a Club Permit Scheme application or renewal signed or issued. You will find more detail on the club permit scheme on the Web Site

<http://www.austin7club.org/>

COMING EVENTS

British & European Motoring Show - Sunday 18 February 2024

Always a great event to showcase our cars, and see lots of delectable vehicles.

Get your car polished up, and there, to promote our Club.

Also a good place to promote Historic Winton.

Hot Air Session / Spares Wednesday 21 February 2024

Found a magic way to get better performance - from your car.

Come and share it with others.

MESSAGE FROM BRIAN GIBBONS

In my Nippy article, in December issue, I provide to you “evidence” of just one of our activities at our Tool Up Days.

That said, we are contemplating having a Friday followed by a Saturday on a fortnightly basis as we would like to encourage our working members to participate at the facility.

Cheers, Brian

DID YOU THROW OUT THE MAILER IN DECEMBER?

It had your Renewal of membership form attached.

Please read the Renewal Form carefully and correct any entries that are incorrect and PLEASE add your email address if there isn't one.

BRITISH & EUROPEAN MOTORING SHOW 2024
OPEN TO ALL VEHICLES MANUFACTURED IN THE UK & EUROPE.

Proudly Presented by THE ASSOCIATION OF MOTORING CLUBS (AOMC) Supported by THE RACV

Celebrating 125 years of Fiat
Celebrating 60 years of the Mercedes Benz Pagoda
Display cars from 9.00 am
Spectators from 10.00 am
Event details 0473 832 277
For site plan and more info:
www.aomc.asn.au/britishandeuropen
fb.com/infoaomc

Sunday 18th February 2024
Yarra Glen Racecourse Armstrong Grove, Yarra Glen

COMING EVENTS

2024 Progressive Lunch
Sunday 25 February 2024

THEME "MUSIC"



Morning Tea at David and Julie Ellis-Jones's house

3 Adams Avenue, Rosebud

Commencing at 10.30 am

BYO chairs, tables and coffee and tea

Scones, jam and cream plus nibbles provided

Lunch at Colin and Helen Jordan's house

11 Alexandra Crescent, Rye

Commencing at 12 noon

Finger food

A selection of wines and drinks to be included

Afternoon Tea at Paul and Leanne Goethel's house

182 Eromosa Road East, Somerville

Commencing at 3 pm

Selection of sweets with tea and coffee

IMPORTANT email socialsecretary@austin7club.org for your intention to attend



Pay on the day **OR**

into A7 General Account BSB 083 323, Account 81 131 6316 using

2024 PROG -"Your Name"

COMING EVENTS

Tool Up at Austin 7 Heaven - SATURDAY 2 March 2024

A *new format* just for SATURDAY Tool UP. Come in whatever part of the day suits you. Sandwich and drink refreshment will be available all day

Monthly General Meeting Wednesday 6 March 2024

Got news about a past or coming event, or had progress on an Austin 7 revival—come and share your news.

Also hear about progress in HISTORIC WINTON 2024.

Pick up any Spares you need for your A7.



Austins Over Australia 2024

Thursday 7th March to Monday 11th March 2024
in Orange, NSW



A programme of events showcasing the beautiful city of Orange, our Austin Motor Vehicles, and a time to catch up with old friends and make new ones.

Contact details for this event:

Tony Groom, Tour Director AOA 2024

Mob: 0412 036 774

email: AOA2024@amvcnsw.com.au

Spares / BBQ Saturday 9 March 2024

Browse the Spares, buy a few, then ask a knowledgeable member how to fit it whilst munching a snag. A great time to share stories.

Perhaps consider talking to someone about a potential role at HISTORIC WINTON 2024.

COMING EVENTS

Hot Air Session / Spares Wednesday 20 March 2024

Found a magic way to get better performance - from your car.

Come and share it with others.

URRRS

Wednesday 27th March 2024

Through the exhaustive efforts of our fellow member John Neve

we have been granted the privilege of visiting

The Australian Synchrotron/ANSTO Research Facilities

at the Monash University Clayton Campus

The number of members joining this visit will be very limited
(number to be confirmed) after which we will create a waiting list.

The cost will be \$21.00 per member, potentially lower if we
can negotiate a higher visiting number.

Full details will be published in the March edition of the Light Shaft

Expressions of interest invited now

Contact John McMillan

Mobile 0408 994 510

Email: mcmillanjp9@bigpond.com

For the last 21 years my wife has been complaining about me not putting the cap on the toothpaste.

Last anniversary I decided to change this bad habit and make my wife happy. I was expecting that she would thank me, but she never did.

Finally last night she said “Why have you stopped brushing your teeth?”

Marriage is a difficult relationship, I tell you!

HOT CROSS BUN RUN - GOOD FRIDAY 29 March 2024

**Annual Charity Event: Generous donations collected for the
Children's Hospital Good Friday Appeal**

WHERE - Rosella Oval / Picnic Area – Braeside Park

Enter Braeside Park from Lower Dandenong Road. Rosella Oval is the last oval on the left hand side before the exit back onto Lower Dandenong Road. Please note this is a ONE WAY circuit. Lower Dandenong Road, Braeside. Melway Map: 88 E8

Come early to get try to park all our the cars together as a club. Look for the Austin 7 flag banners.

WHEN Time. **9.00am till 2:30pm**

BYO Picnic chairs and tables, Lunch and drinks, sunscreen.
No Alcohol is permitted.

The organisation of this event is shared by the Veteran Car Club Vic (VCCAV), Vintage Drivers Club (VDC), Classic & Historic Automobile Club of Australia (CHACA) and the Austin 7 Club Inc.

This year will be hosted by the **TBA** Please come along and join in our club display and have a great day out with fellow car enthusiasts and enjoy the multitude of superb vehicles that are on display.

Free Hot Cross Buns, tea and coffee provided, along with scintillating conversation.

Housekeeping: No animals are allowed in the Park.

Please take your litter home with you.

Do not feed or handle the wild life.

Drive very carefully on the oval.

Braeside Park is closed on CODE RED fire danger days and the event would be cancelled.

COMING EVENTS

LEARN TO DRIVE DAY - Sunday 7 April 2024

This event has been proposed by Greg Hallihan. The venue will be Graeme Logan's front paddock at Merricks North, which is familiar to many members as a popular site for Club Motorkhanas.

The concept is to give members the opportunity to bring along their vehicles (A7s, mudcars and anything appropriate) to be driven in a safe environment by family members. We encourage the younger members or non driving members (eg lady partners) of our club to take the wheel under the guidance of other family members. There will be basic witches hat courses configured for negotiation by the drivers. This is to be a fun event (and not a competition), so that family members (other than the regular driver) can "get the hang of" driving our old, muddy or other interesting cars.

We especially encourage all grandparents to bring along their grandchildren for a fun day (driving Pop's funny car).

Greg Hallihan would appreciate some assistance with setting up courses (as this is a new thing for him).

Bring along a picnic lunch and some chairs (Graeme and Bev will provide the shade and facilities).

Date: 7 April 2024

Time: 10am

Where: 192 Bittern-Dromana Road, Merricks North (look for the Austin 7 sign).

Enquires Greg Hallihan 0409381900



COMING EVENTS



Swan Hill Border Run 2024

13th to 16th Sept, 2024

*Save the
date*



Christmas Card Recycle

It is time to recycle all unwanted
Christmas Cards at the Clubrooms

There will be an Australia Post Box
aptly titled

“ RECYCLED CHRISTMAS CARDS HERE”

These cards are recycled at The
Orchards Aged Care in Templestowe,
where Helen Crellin volunteers as a
craft coordinator

Thanks in advance

The photos are examples of the artwork
craft.



COMING EVENTS

It's time to consider how you can get your Austin 7 to Historic Winton 2024, AND help out as an official, but also potentially participate in:-

- ⇒ The Friday Tour
- ⇒ The Display at the track, either in the car park, OR in the Corporate Pavilion
- ⇒ Sunday Parade Laps

If you have a competition A7, and do not want to compete, display in the Competition Paddock may also have potential.

47th HISTORIC WINTON
25th and 26th May 2024
GIGANTIC CAR SHOW
 CLUB DISPLAYS | PARADE LAPS | TRADE SITES

www.historicwinton.org
 Winton Motor Raceway, Benalla, Victoria

BENALLA RURAL CITY | The Austin Seven CLUB | MOTORSPORTS AUSTRALIA | AUSTRALIAN MOTORCYCLE ASSOCIATION

Austin Seven Club Inc. A0003290N | Photo - Peter Knight Photography

CLUB VISITOR

If you know of a Member who is unwell or in Hospital please contact Bruce Walker, our Club Visitor. He will visit or send a card to the Member.

Contact Bruce on brucewalkerartisan@gmail.com

9807 1729 or 0409 410 700.



CONSIDER VOLUNTEERING

FOR the 47th HISTORIC WINTON

Historic Winton is the largest event that the Club conducts each year, and it is the event that we get the greatest participation by:

- ⇒ *Club Members, and their families, as Officials, and*
- ⇒ *Club Members, and former members, as Competitors.*
- ⇒ *Club Members, and their families, as Spectators*

There is a job for everyone, some of these do not require attendance at the event.

It is also worth pondering that this event is also an important event underpinning the finances of the Club.

BUT, it is also a great pleasure to see so many people enjoying themselves.



**HISTORIC
WINTON**



PAST EVENTS - 2023 BOB BOOTH PUB CRAWL

Friday 3rd to Sunday 5th November by Kathy Hore

A rainbow of shiny Austin 7s and their proud owners converged on picturesque Castlemaine on Friday, November 3, for the opening of the 2023 Bob Booth Pub Crawl. Maria and Colin Cheesman crafted an excellent experience for everyone. Anticipation was in the air as folks ambled from the Castle Motel to the Cumberland Hotel for the first shared meal. The chef and staff did an admirable job feeding a capacity crowd in style. Recognised by UNESCO as a notable region for gastronomy, Castlemaine, Maldon and surrounds clearly held much to look forward to.

After the briefing, the Saturday morning run began with perfect weather and smooth roads. Colin, our host at the Victorian Miniature Railway, gave an extensive history of the project, moving the listeners from the parking lot to the clubroom to the warehouse to the tracks. After morning tea, he took a break to run the children and the young-at-heart up and down the 7 1/4" gauge tracks in a very miniature car pulled by a replica miniature engine. Doffing his conductor's cap, Colin explained how the nearly complete replica of the Maryborough Train Station came to be. Part of the eight-year project may be reached in December with the completion of the station. March 2024 is the projected opening of the Victorian Miniature Railway.

On the road again, the Austin 7s proceeded through Castlemaine Diggings National Heritage Park, through Chewton, to Garfield Water Wheel Leanganook Track. An ample and scrumptious wrap lunch was served, followed by quite a variety of rich slices.

Pennyweight Flat Children's Cemetery, the next stop, was sobering and confronting, while also being historically fascinating. Life in the goldfields was especially hard on the health of children, so at the height of the era a cemetery was set aside for the burial of at least two hundred children. Only the faintest traces of stone remembrances are left, but the mood is sombre as visitors imagine the brief, hard lives of the children.

PAST EVENTS - 2023 BOB BOOTH PUB CRAWL

Breezes and grand views of Castlemaine raised the spirits of the Seven drivers parked around the hilltop Burke and Wills Monument Lookout. After perusing the informative historical markers, the group left to regroup at 3pm near the Castlemaine Train Workshop. Here an attractive feature of the Pub Crawls appeared. During this open-ended afternoon, folks could tour the train workshop, visit the Botanical Gardens, browse the 100-stall Mill antique and variety mall, or enjoy galleries, all while enjoying crafted ice cream or coffee. Viva flexibility.

The Historic Five Flags Hotel in Campbells Creek was the setting for the Saturday night group dinner. This writer's end of the table was scene to mechanical and parts talk; good-natured repartee about the minor bump a rolling 7 gave a modern; and deep sharing about things of importance. It is a testament to the club that an accident in a parking lot does not cause hard feelings and loss of fellowship.

Sunday was awesome. The 54-minute run to Maryborough took the procession of Austin 7s through Guildford, Newstead, and a morning tea stop near the Tullaroop Reservoir. As picnic baskets opened, the array of homemade goodies in evidence would have made any CWA member proud. Generous sharing was going on, of samples and recipes. The mown lawn running down to the water was lovely.

A warm welcome and two amazing collections awaited the group at the property of Val and Daryl Maffescioni. Maria presented a bouquet and a mug to the couple before the tours proceeded. The doll collection would be sure to jog memories of anyone who ever visited. Each doll, and there were hundreds, was beautifully dressed, especially the baby



PAST EVENTS - 2023 BOB BOOTH PUB CRAWL

dolls. A huge fleet of fancy prams held the baby dolls that weren't displayed in cribs or highchairs. But dolls were only the beginning. Rooms of miniature villages lit for Christmas, followed by miniature doll houses from several era and cultures, led into Cabbage Patch, Barbie, and wedding doll displays. The men found a less decorative but thoroughly dazzling variety of cars and all things mechanical in the Maffescioni collection.



Only three miles down the road were the cool and inviting Phillips Gardens in Maryborough. Gathering in the welcome shade of huge old trees, hungry



PAST EVENTS - 2023 BOB BOOTH PUB CRAWL

Austin Seven folks gratefully chose their pick of delicious sandwiches brought in by Maria and Colin. And, again, the slices were "to die for."

Back in the Austins, the group proceeded for a two-minute drive to the Maryborough Railway Station for a quick look. Then the cars and occupants lined up for group pictures in front of the impressive facade of the station. Fun fact: The Maryborough Railway Station was meant to have been built in Maryborough, Queensland, but was shipped to Victoria and installed. Their loss, our gain.



The next stop, the Mount Tarrengower Lookout, was only reached by the confident and intrepid. A significant group waited at the bottom of the hill and attracted numerous admiring glances from passers-by.

Together again, the cavalcade proceeded to the lovely property of Daniel and Rachel Cheesman, and their sons Miles and Fletcher. From Aussie animal-stamped biscuits to chocolate-dipped strawberries, the boys, friends, and family created a memorable afternoon tea, set in shade off the wrap-around garden. Sweet pea bouquets were surrounded by trays of sandwiches, biscuits, scones, strawberries, slices and more. The in-ground trampoline attracted a few folks away from the food.

A special feature of the afternoon was the opportunity to hear Ilona Booth browse through her photo books of a club trip to the northern tip of

PAST EVENTS - 2023 BOB BOOTH PUB CRAWL

Australia decades ago. Several photos featured Sevens waiting to be winched out of mud. The hospitality of the entire Chessman family was appreciated by all.

Castlemaine Railway Hotel, the Sunday evening dinner spot, exuded the warmth and charm of the historic pub that it is. Despite being well-fed all day, the club members savoured the excellent offerings. All that fresh air during motoring be appetite - inducing. Some talk was overheard of the Monday Melbourne Cup and Bev's two tips, which increased the fun for everyone.

Monday 6th November by Bev Logan

Morning tea was in the park at Clunes. Graeme & I were very happy to see Robert & Philip, the owners of a 1923 Rolls Royce that Graeme did the woodwork on. They live in Clunes and had come into town for coffee. Graeme started work in 2012 and the finished frame was delivered in January 2014. The frame was pretty well stuffed. The car was finished this year and registered in April.

From Clunes we went to the Lambley Gardens and Nursery where we were given a garden tour, by the owner David Glenn. The gardens were beautiful with rows of trees, hedges, flowers such as sweet peas, tree peonies and spectacular vistas. We visited the Nursery where plants, seeds, books etc. were for sale.

Lunch was in Creswick with everyone buying their lunch from various places.

After lunch we were supposed to go to Daylesford and Hepburn Springs but due to the tragic accident in Daylesford this was given a miss.

Vaughan Springs was on the programme but a few of us went to the Creswick Woollen Mills instead and purchased some goodies.

PAST EVENTS - 2023 BOB BOOTH PUB CRAWL

Dinner was in the Garden Room at Buda Historic Home & Garden, with the theme for the night being, "Garden". Len Forster was a watering can; Russell Dickson the lawn man; Helen & Michael Shegog- blood & bone (Michael made their outfits, Helen's was bloody and Michael had black bones printed on his outfit); Chris Athey was a gnome; Glynis Gibbons a bunch of flowers and Margaret Rogers & Helen Jordan were butterflies. There were fresh and artificial flowers of all sorts mostly adorning different head dresses & baskets.



Best male costume, was the Lawn Man (Russel) and best female, the Bunch of flowers (Glynis).

Our thanks to Maria & Colin, their daughter, Rachel, their son-in-law, Daniel and two grandsons, Miles & Fletcher. (See photo above of Maria and the two grandsons) The weekend was fabulous, visiting many places, seeing new things, having a wonderful time and of course the camaraderie with fellow participants.

PRESERVING OUR CLUB HISTORY

ARCHIVIST & CURATOR

The Club needs some people to carry on the excellent work done by Laurie Allan, who managed to scan all our collection of Club Newsletters, and catalogue all these documents, and many more, and create records of much of the collections of memorabilia that the Club has.

However, this needs much additional work, but is not urgent. That said, any volunteer/s can work at their own pace.

The primary aim is to progressively make Club Members aware of the vast amount of information that is available.

In addition, the Club needs a volunteer, to work in partnership with the Archivist, to act as a Collections Curator, or an Exhibitions Curator, to address how the Club should properly look after its collections, and also to progressively create adequate descriptive material so that our members can understand the relevance, and importance, of each item in the Club's collections.

An important early project is to create suitable descriptive elements to accompany all the items in the Dickason collection, and also convert the extensive record of this collection into a form that is readily available to Club Members and visitors.

Similar descriptive items are also needed for all of the Club's displays, including our trophies collection.

It is also planned that all our extensive electronic records of our collections should be progressively made more available to members, and that these records are systematically supplemented by the significant quantity of additional Austin 7 history that is being steadily researched by many Club Members.

Perhaps some of these roles could suitably become part of a study for a person seeking a tertiary qualification.

For more talk to Robert Humphreys, at a meeting, or at 0427 772 281.

SNIPPETS OF HISTORY

Nippy at Laverton June 1955 Peter Gray

Tony Johns wrote - I am busy searching through my collection of Australian Motor Sports magazines and thought you may be interested to learn there was a genuine Nippy chassis competing at the Club's 9 Chain sprint, June 1955, driven by Peter Gray.

Rob, do you have any details of Peter Gray?

Tony, any photos of his special? I have not seen his name listed in any of the hillclimb or race meeting programs in my collection. This is exciting as it is a new car to me.

The article also tells us John MacLeod was the next owner of the Fred Thorne Austin.

Frank Walter's electronic timing gear also gets a mention.

Editor I could find no ready reference to Peter Gray, so perhaps someone else may have an idea.

Regards Frank Walter's timing gear. Frank's stop watch destroyer was a simple fail-safe contrivance that connected the starting spoon for sprints, to a solenoid that activated a stop-watch.

Frank later contrived timing equipment used at early Phillip Island meetings, where the Club not only provided observers/communication, but also provided some flag marshalls.

Frank was also in Charge of the Club's communications team at Sandown, but was often called (often in panic mode) by the Melbourne Uni Timing Team, to go and solve a problem with the track timing equipment.

Frank was also involved in the Lake Eyre record attempts by Bluebird in 1964, which is a story in itself.

AUSTIN CAR CLUB**VICTORIAN JUNIOR CAR CLUB****VICTORIAN SPORTING CAR CLUB****From Tony Johns**

The Austin Car Club, formed on 4 July 1928, held its first committee meeting at Davey's Service Station, 71 – 73 O'Connell Street North Melbourne. Tom Davey was elected President and C Higgins Secretary.

Their first outing, a picnic to Warrandyte on Sunday 22 July, started from Alexandra Avenue, South Yarra. **The Car** magazine reported President Davey led the convoy along the route, the popular little Seven created great interest, and never before in the history of motoring in Victoria has the public seen so many "Babies" out on their own. Naturally they were chaperoned by their elders (The Austin 14).

These picnic runs were more social events than competitive trials, races or hill climbs, like Kalorama back in the 1960s.

In August 1929 the club held a 12 Hour Trial and petrol economy test attracting 22 starters, travelling 254 miles from Melbourne to Frankston and then on to Gippsland. Starting and finishing at Daveys Service Station. The entrants set off at midnight on Friday with a stop for breakfast at Mirboo North before returning to North Melbourne 12 hours later. T O Gaze, the outright winner was awarded the trophy donated by Austin Distributors , recording 56.4 miles per gallon. He also won the gold cup for best performance, having completed the journey without loss of points or mechanical trouble.

It would be interesting to learn if TO Gaze was a relative of Tony Gaze the RAF pilot and famous racing driver?

The Victorian Light Car Club mentioned in the May 1930 issue of **The Car** magazine.

“It is understood that the Austin Car Club intends changing its title to that of the Victorian Junior Car Club. It is to be hoped that no confusion will arise through this change, owing to the similarity of that name and that of our club”.

The reason for the name change was to expand the club by accepting all owners of light cars not just Austins.

Thirty-four THE CAR December 15, 1930.

VICTORIAN JUNIOR CAR CLUB

Office-bearers for Season 1931:

President—L. V. Drill.
 Vice-President—R. Graham Tucker.
 Sports Captain—J. A. Day.
 Hon. Secretary—C. I. Higgins.
 Hon. Treasurer—B. H. Stewart.
 Press Correspondent—B. Fuller.
 General Committee—J. E. Hennessey, H. Burkill, C. R. Dickason, R. C. May, G. Bastow, H. L. Sinclair, R. Lea-Wright, D. Farndon.



Club Office:
 415 Elizabeth Street, Melbourne, C.I.
 Phone: F 6492.

Entrance Fees and Subscriptions:
 Entrance Fee, 10/6, which includes Car Club Badge for Radiator.
 Subscription, 10/6 per annum, payable in advance.

Perhaps the most important event the renamed club organised, was the hill climb at Moonda Estate, five miles south of Frankston and owned by T M Burke. A charity event with the proceeds going to aid the Lord Mayor's appeal for hospitals. The montage published in **The Car** magazine confirms the photo of the three sports Austins on display in the clubrooms was taken on Sunday 26 October 1930. However the report in the Melbourne Age newspaper that is worth reading.

“The contests were thrilling, the final of the special challenge match being won by four inches by C R Dickason (Austin SC) from R C May (Austin SC), who was placed second, and R G Tucker (Triumph SC), third. J May (Morris Special) was scratched. The contestants drove at a terrific pace, and were three abreast for most of the journey”.

The Club is fortunate to have photos from this event in the Cyril Dickason Collection.

AUSTIN CAR CLUB

VICTORIAN JUNIOR CAR CLUB

VICTORIAN SPORTING CAR CLUB



Frankston Hill Climb Photo

Bill Sheehan has identified the drivers as Daryl Burkett #14, Clarrie May in Waite 1928 Austin #16 and Cyril Dickason #15.

The third and final name change was announced in the March 1935 edition of **The Car** magazine when the committee proposed to change the name from the Victorian Junior Car Club to the Victorian Sporting Car Club (VSCC). This meant that full membership was granted to people possessing cars of any capacity.

PAST EVENTS

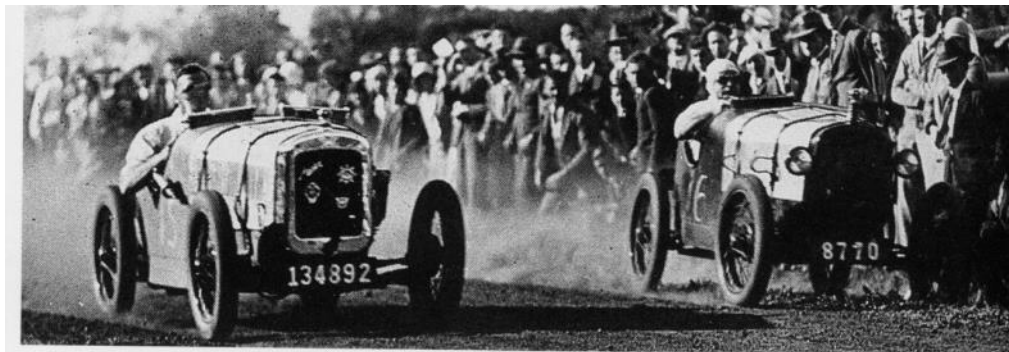

A tense moment on the race-track! Cyril Dickason sitting grimly in his vehicle passes Clarrie May; all wind resistance was lessened by lowering the small windscreens. No bitumenised road surface in those times.

The VSCC ran races at Phillip Island and hill climbs at Mitcham before they established the very popular Templestowe hill climb in 1952, that many club members competed in over the years until its closure in 1970. In 1976 the VSCC was wound up and became part of the Light Car Club of Australia (LCCA.)

Editor's Notes

It is interesting to observe that the Dickason collection has a number of trophies that attest to the various changes to the name changes of this "club".

The two photos on Page 37 are

1929 Clarrie May driving Austin 7 Super Sports #16 Reg No 8770—the ex Arthur Waite car that won the First Australian Grand Prix.

Cyril Robert Dickason driving Austin 7 S/C #15 Reg No 134892

November 15, 1930.

THE CAR.

Nineteen



THE V.J.C.C. HILL CLIMB AT FRANKSTON IN AID OF THE LORD MAYOR'S FUND.

(1) Miss I. Simmonsen in Ladies' Event. (2) J. Bernadou in Baby Triumph. (3) Hittock. (4) C. May wins special racing car event. (5) Hittock. (6) E. Bastow, in Morris Minor, who won both Standard Tourer events and Standard Sports, and Miss N. Bills, who won the Ladies' Event. (7) Arthur Terdich takes the wheel of Scott's "Ascot." (8) Mick Chappel, just before his car turned a somersault at the Hair Pin Bend. (9) C. May, winner of Championship. L. Wiseman astride the latest supercharged Baby Austin he brought back from England, and which C. R. Dickason, on right, drove. (10) Gordon Nielson and Miss Simmonsen. (11) B. Sutton in Morris Special. (12) I. K. Laidlaw and officials at the start.



**"Bacon Slicer" starter motor
1923-29**

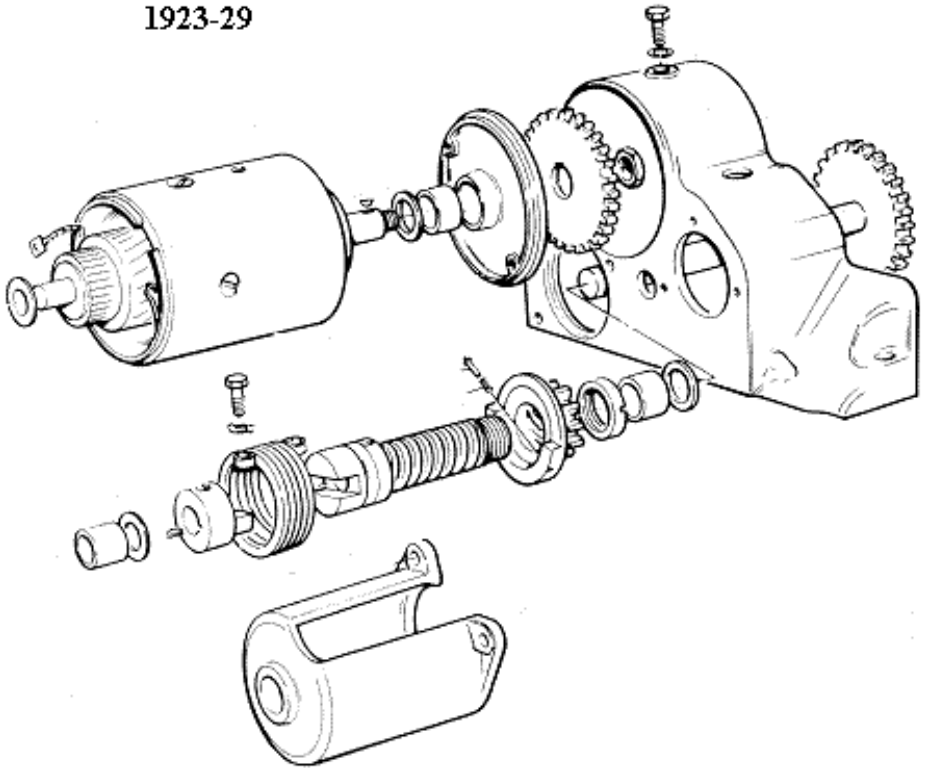

Thought I would share this diagram with all those who have early starters.

GEARBOX REPAIRS

To ALL AUSTINs, including F.W.D.

Special Ratios and Standard Ratios

Austin 7 - 4 speed boxes with better ratios from \$1,700

Changeover or yours rebuilt

John or Ben Needham

OLD CAR GEARBOXES P L (03) 9553 3203

Spares for your Austin 7 Brian Gibbons

Saturday Shoppers!

Save On Needed Commodities at Foy's

Lower Prices on Motor Accessories, etc.

Red Cycle Tyres - 4/9 ea.

For best working floor TYRES you should do better than anything you can buy. TYRE - Recommended for Saturday morning only. Saturday Special is 6d.

Hardening Compound 2/-

Chemical Compound for the professional. Undercoat or suitable surface for an absolute bargain. Available for same morning road stock from 6d. Saturday Special is 2d.

Brake Lining 1/4 foot

Now is the time to repair those Frayed Brakes. Take advantage of this special offer and do them. Quantity. Complete these prices: 1 1/2 ft. x 5 1/2 in. is 6d. 2 ft. x 5 1/2 in. is 1/4. 3 ft. x 5 1/2 in. is 1/4. 4 ft. x 5 1/2 in. is 1/4. 5 ft. x 5 1/2 in. is 1/4. 6 ft. x 5 1/2 in. is 1/4. 7 ft. x 5 1/2 in. is 1/4. 8 ft. x 5 1/2 in. is 1/4. 9 ft. x 5 1/2 in. is 1/4. 10 ft. x 5 1/2 in. is 1/4.

Chassis Enamel 1/-

Montrose Black CHASSIS ENAMEL is a quick drying anti-rust preventive black enamel suitable for spraying or brushing on. Also, painting under-carriage, etc. Saturday Special is 10d.

Duco Polish - - 1/6

KAUFER'S DUCCO POLISH. Take advantage of this special offer in purchase of this polish and prove its worth at a Saturday Special is 6d.

Austin 7 Head Gaskets 2/-

Austin 7 Head Gaskets. For this date and only we are offering at a remarkably low price. Austin 7 Gaskets for 2/-. We have a limited supply only.

Lower Price Levels On Men's Wear



Men's Winceyette Pyjamas - - 7/11

These Perfect ones are made in three Men's Winceyette Pyjama styles, comfortable and strong, in grey and attractive colored stripes, a good quality material in a full cut. The low price is hard to beat. Blue Ribbon Special is 11s each.

Men's Poplin Fashion Shirts - - 7/11

These An excellent quality Fashion SHIRT in a fine quality poplin, with new and fast-colored stripes, giving a smart appearance. Wash collar to match, and offered at a special price. Blue Ribbon Special is 11s.

Elastic Braces - - 1/- pair.

These Strong Elastic BRACES are essential for comfort and they are specially priced. Printed with leather ends. They are thoroughly capable of withstanding ordinary hard work. Blue Ribbon Special is 10d.

Men's Fur Felt Hats - - 18/6

These To complete the outfit provided by a well-tailored suit, a smart hat is an essential. There is no doubt that in high-grade Fur Felt HATS, in the latest styles, will smart you in nearly bound edges. Offered at all the leading stores. Blue Ribbon Special is 18s.

All Wool Bathers - - - - 8/11

These Best Summer Dress will give you with them from the water for frequent dips in the ocean. Be prepared, because you'll find of these All Wool Heavy Ribbed One-piece BATHERS, with white top and colored band and back patches. An essential item. Blue Ribbon Special is 11s.

Cashmere Socks - - 3 pairs for 5/6

These Wonderful Value is offered in Men's Black Cashmere SOCKS, the famous "Woolen" brand, comfortable and retaining their shape. Washable stockings will undoubtedly be offered at this price. Blue Ribbon Special is 5 pairs for 5s 6d.

Smart Wide-end Ties - - - - 1/11

These Smart Wide-end Ties are now all in evidence. You can't have better than they always look well. A first value not to be overlooked. Blue Ribbon Special is 11s and 2s 6d.



Lower Prices on Sporting Goods - -

For Tennis - - - -

Building's "Grip-and" TENNIS RACKET, Superior. Price 2/6.

TENNIS SCORE BOOKS AND TABLETS, Green Book, 1s. 6d. Green Table, 2s.

Reliable Cricket Bats - - - -

Cricket and Hockey CRICKET BATS, made of the finest English, straight-grained timber for a long life. The "Antograph" Superior Extra Special, 1s. 6d. "Antograph" Specialty, 1s. 6d. The "Kangaroo" was an arrival in England in 1901 in the 1st year, and is made of superior timber. "Selected" 10s 6d. Specialty Selected, 12s 6d.

Cricket and Hockey CRICKET BATS, made by Arthur Handley, every kind of cricket, from the Special Australian, 10s 6d. British Blue Superior, 10s 6d. Practice, 10s.

Cricket and Hockey CRICKET BATS, "Evoque" XXXX, 10s 6d. "Evoque" XX, 10s 6d. "Evoque" X, 10s 6d. SPORTS SECTION-GROUND FLOOR, ST. GEORGE'S TERRACE, LONDON, W.C.

Playing Cards - - - -

These Superior PLAYING CARDS, highly decorated, containing 52 different faces, 2000 Games, 1s 6d per packet.

For all your POOLERS and SERVICERS in all-weather packet. 1000 cards and 1000s, 2s 6d per packet.

REARVIEW DEPARTMENT - FIRST FLOOR.

Traced Pure Linen Sets 1/3 ea.

Traced Pure Linen and Five Pure Linen Sets, 1/3 ea. 4, 6, 8, 10, 12, 14, 16, 18, 20, 22, 24, 26, 28, 30, 32, 34, 36, 38, 40, 42, 44, 46, 48, 50, 52, 54, 56, 58, 60, 62, 64, 66, 68, 70, 72, 74, 76, 78, 80, 82, 84, 86, 88, 90, 92, 94, 96, 98, 100.

For Saturday Morning Specials Men Foy & Gibson's BLUE RIBBON SPECIALS

Traced Cotton Baby Pillows 10 1/2

Traced White Cotton Baby Pillows 10 1/2

An alternative source for head gaskets. Pre war advertisement published in the Daily News, 3/10/1930. Foy and Gibson advertising - Austin 7 Head Gaskets this weekend only for 2/- each. From Tony Johns.

SUB-COMMITTEES 2024

HISTORIC WINTON SUB-COMMITTEE

Co-Chairs - Peta Lee —Secretary of the Meeting, Entry Secretary & CoChair, Len Kerwood CoChair, Noel Wilcox, Tony Press (Minutes), Mike Belcher, Colin and Maria Cheesman, Paul Goethel, Robert Humphreys, Faye Stevens, Ron Crellin, Alan Barnes, Leanne Goethel, Yolanda Filip, Graeme Logan, Bruce Rogers, Michael Lambert, Bernard Snoodyk

OST SUB -COMMITTEE

Chairperson – Jason Stock - Chairman -: Leanne Coakley - Secretary, Cooper Schweiger, Alicia Randle, Mark Filsell, Declan Caldercoat, Jesse Stritch.

SPARE PARTS SUB-COMMITTEE

John Shiells (Facilitator), Graeme Logan, Janne Humphreys (Spares Treasurer), Neil Rickard, Courtenay Rumble, Roger Nation, Alan Barnes, Richard Kempster, Graeme Burbidge, Robert Humphreys/John Neve (Bill &stock entry), Ted Thompson, Brian Gibbons, Bruce Shearer, David Easton, Yolanda Filip, Mike Belcher, Michael Lambert, Tony Press (Minutes)

SPARE PARTS MANAGEMENT SUB_COMMITTEE

John Shiells (Facilitator), Brian Gibbons, Rob Humphreys, Tony Press (Minutes)

SPARES MAIL ORDERS

mailorderparts@austin7club.org

Robert Humphreys/Janne Humphreys (03) 9583 6316

CLUB VISITOR

Bruce Walker 9807 1729, 0409 410 700

PUBLICATIONS and ARCHIVE SUB-COMMITTEE

Robert Humphreys, John Neve, Robert Taylor, Allan Tyrrell, Tony Press

ARCHIVIST

Vacant

CURATOR

Vacant

LIGHTSHAFT MAIL OUT SUB-COMMITTEE

Manager - Russell Dickson, John Shiells, Robert, Janne & Fiona Humphreys, David, Katrina, Alice & Georgia Easton.

TECHNICAL ADVISORS

Model & Parts Identification, Bodywork & Literature

Bill Sheehan 0435 582 294

Tony Press 0409 948 430

Mechanical and Engineering

Tony Press 0409 948 430

Racing and Special Construction

David Lowe 0458 172 494

O.S.T.

Jason Stock

Spares Engineering Review

Russell Dickson, Denis Hourigan, Tony Press (minutes)

SPEED EVENT SPOKESPERSON

Phillip Hallo 0413 185 576

Noel Wilcox 5428 2689 AH

Motorsport Australia State Council Delegate

Jason Stock

MA HISTORIC MOTORSPORT PROMOTERS GROUP

Noel Wilcox

CLUB WEBSITE Tony Press, Manager

HW WEBSITE Leanne Goethel, Manager

AOMC DELEGATES

Len Kerwood and Robert Humphreys

FEDERATION DELEGATES

Alan Barnes (Country volunteers reqd)

CLUB BUILDINGS OWNERS CORPORATION DELEGATES

John Shiells, Robert Humphreys, John McMillan

CLUB PERMIT OFFICER

Russell Dickson, Robert Humphreys (Deputy)

URRRS EVENTS COORDINATOR

John McMillan

CLUB LIBRARY

David Easton

EVENTS CORDINATOR

Vacant

AUSTIN 7 CLUB INC. - COMMITTEE 2024

PRESIDENT	Len Kerwood	president@austin7club.org	9435 2544
TREASURER	Paul Goethel	treasurer@austin7club.org	0412 534 131
SECRETARY /VICE PRESIDENT	Glynis Gibbons	secretary@austin7club.org	0427 837 555
MINUTE SECRETARY	Tony Press	minutesecretary@austin7club.org	0409 948 430
PROPERTY OFFICER	John Shiells	propertyofficer@austin7club.org	0403 228 559
EDITOR	Robert Humphreys	editor@austin7club.org	0427 772 281
MEMBERSHIP SECRETARY	Russell Dickson	membership@austin7club.org	0409 577 215
COMPETITION SECRETARY	Jason Stock	competitionsecretary@austin7club.org	
SOCIAL SECRETARY	Michael Lambert	socialsecretary@austin7club.org	0409 992 675

Austin Seven Clubs Association

The Online Archive

Handbooks, Parts Books, Body Parts Book and lots more.

Just download it to your computer - all part of membership of the Association.

More being constantly added.

These references are a great way to identify parts for your Austin7.

Also it may help to determine the year of the various parts.

An original Parts Book, for your model is one of the most valuable resources, especially for remote members.

An original Handbook is also a handy reference.

NEW FROM SPARES

SPARES

PLEASE come to Spares **with a list prepared beforehand**, to speed up being served, and make it easier on our volunteers.

Please be prepared to follow any current COVID restrictions.

PLEASE When you visit Spares try to make all your purchases **in a single transaction.**

This makes the book-work much easier for our volunteers, and respects other members who also want to make purchases.

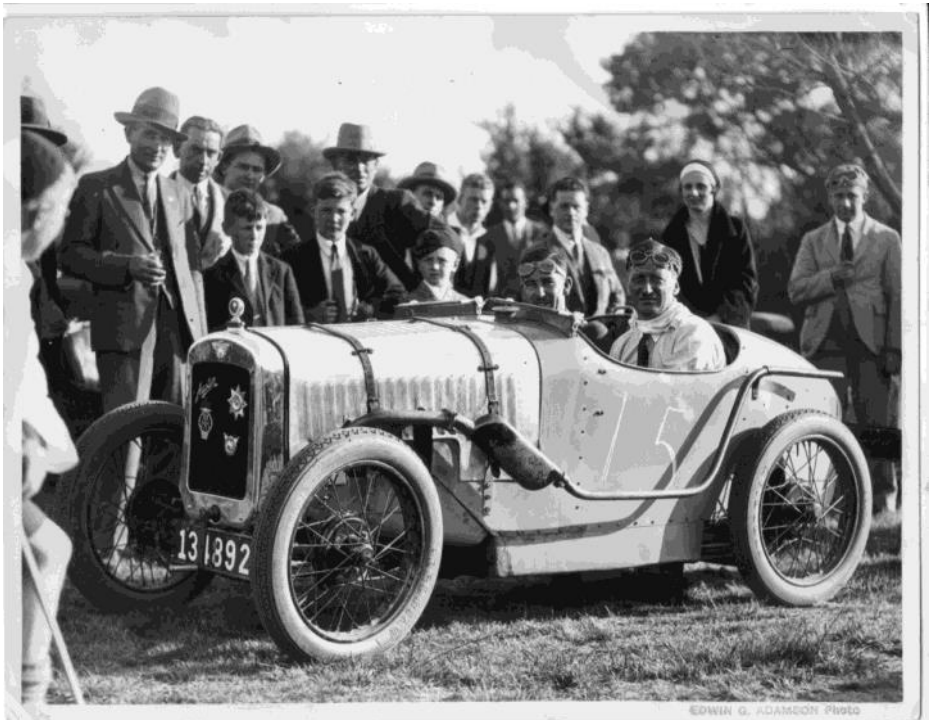

A rare photo of Dickason in the passenger seat.

MAIL ORDER PAYMENTS TO AUSTIN 7 CLUB SPARES

Payment for parts is preferred by Direct Deposit.

Please note Spares Banking Details, located at the bottom of our Invoices.

Bank branches are making banking cheques difficult, and Credit Card payments, without card, are a risk to the Club and the member.

Robert & Janne Humphreys- mailorderparts@austin7club.org

The Club proudly supports Penrite Oil and stocks Penrite Vintage Car Oils exclusively in Club Spares.

Unfortunately, not available by mail order.

MARKET PLACE

Market Place advertisements will normally appear for FREE in two consecutive Lightshafts Editor



FOR SALE

Austin 7 utility.

I am asking \$3,500 it is in Shepparton

my no is 0418 184 918

MARKET PLACE

FOR SALE - Melbourne.

Austin 7 Meteor 1929 Special.

Pressure Fed Crank Shaft 1 1/2"

Gear Box 3 Speed close ratio.

Diff late 8/42.

Hydraulic Brakes.

12 Volt System.

Austin 7 Instruments.

Extractors 1 1/4" SU

Hood.



\$30,000.

Michael Shegog. 0419 007 033.

shegoga7@gmail.com**FOR SALE - Trailer**

Rugged trailer, with electric brakes ,heavy duty tyres , aluminium planks - takes an Austin 7 with ease, could fit a wider car or mower.

Registered until March 2023. **\$ 2,800**Ken Innes-Irons 0413 744 337 kennetha7@bigpond.com

(See photo in past Lightshafts)

WANTED

A Mark 2 Ruby Windscreen

(Must be MK2 the earlier one does not fit.)

Frame is only required new glass will be cut.

Tim Williams 0427 570 293

MARKET PLACE

FOR SALE

I have the following 3 books for sale.

- ◆ 'Original Austin 7' by Rinsey Mills. One book Mint condition, \$50 and one book Excellent condition, \$45.
- ◆ 'The Austin 7 Manual by Doug Woodrow' in near mint condition-\$75.

John Keane, Blackburn, Melbourne 9877-7754

Bus Hrs Email: oldercarrepairs@bigpond.com

FOR SALE

The following three vehicles owned by Mr Des Chick of Wangaratta will be offered unregistered at auction shortly. Club members are invited to offer for any of these cars prior to auction. Contact trevorchick@yahoo.com

1923 20 HP Rolls Royce

1927 Chevrolet Tourer

1927 Rolls Royce Phantom 1 - project car,
running chassis only



MARKET PLACE

FOR SALE

Austin 7 Sports (Black Bess)

1929 model with some later parts

Body by Bill Sheehan

Recent extensive overhaul by Walter Raschle: in first class mechanical condition

Extensive competition and touring participation as detailed elsewhere.

Don Smith 5422 7335

Car can be viewed at Kyneton \$20,000.

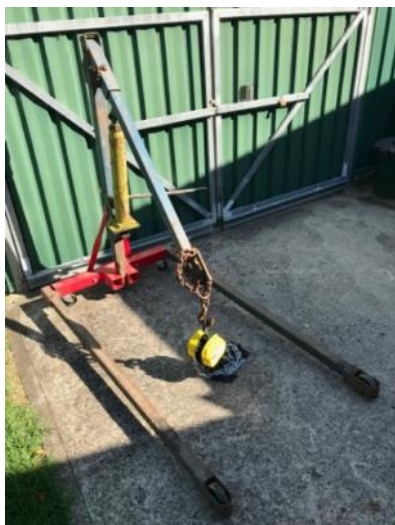

FOR SALE Hoist_Engine Stand

Club Spares Garage - Special tool for sale.

Engine Hoist and Engine Stand Combination

Hydraulic 1 1/2 Ton mobile crane fitted with a stand to hold an Austin 7 engine. (Block & tackle not included)



View at Spares Garage. Pick up only. \$150 ONO

Contact email:

spares@austin7club.org

MARKET PLACE

FOR SALE

My brother has decided to move on his 1930 Chummy. He purchased the car from Peter Mathews a year or so ago, it had been in storage since the Orange National A7 Rally 17 years ago.



I recommissioned the car, rebuilding the starter and charging systems, rebuilt the hydraulic braking system, fitted new tyres, serviced the motor, etc. All mechanicals seemed to be in great condition.

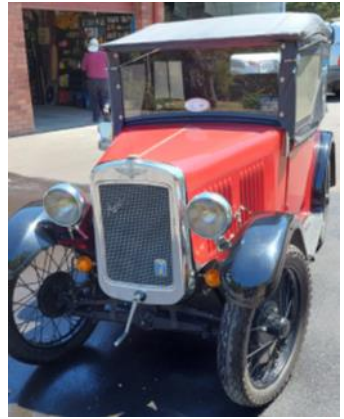

Paint is good to fair, interior, top, side-curtains, etc are excellent. Apparently the original restorer had the engine worked on, it went very well when I drove it. There are a number of spares with it.



The car went through a roadworthy check ok and was put on full reg.



It is now unregistered and will be sold as such.

He is looking for \$25,000 or sensible offers.

Please contact Leigh Whitfield for further details.

0407 884 869 or griffinvale@hotmail.com.

MARKET PLACE

FOR SALE

1929 Chummy Restoration

Offered for sale is the restoration project of the late Neil Johannessen.

This is a Holden body (including the Holden bodyplate).

The car is mostly dismantled. All the bodywork has been completed and painted in Maroon. The paintwork is in good to fair condition.



Almost all of the mechanical parts are available.



The chassis, rear axle and wheels have been restored as have all the instruments and the radiator shell. It currently has 15inch spoked wheels, but a set of original 19" wheels are included.

MARKET PLACE

The engine, gearbox and front-end require restoration as does the trimming, but the hood, side curtains and front seat frames are there.

An easy restorer.

The car can be viewed at Austin 7 Heaven and enquiries through John Shiells.

Asking price \$8,000



FOR FREE

Austin 7 windscreen I didn't want to throw it in the garbage so hopefully someone can use it?



If anyone is interested they can contact me on apr@iprimus.com.au.

We are at Mount Martha where it can be picked up. I don't want anything for it. This Austin 7 Windscreen is in unmarked, good order, free.

Ken Anderson

MARKET PLACE

FOR SALE

1935 Austin 7 tourer

Ready to go

New pressure fed crankshaft

New Pistons plus 0.060"

New Mini valves

New Timing gears

New Electronic Distributor

New Springs

New bushes & Kingpins

New radiator

4 speed Needham gearbox

Perry Exhaust



LED blinkers

5 new tyres

12 Volt generator

New trim and roof

Hydraulic brakes

\$\$ BEST OFFER \$\$

John Franklin 0418 340 433

FOR SALE. ALL AUSTIN SEVEN ITEMS.

Windscreen, for saloon, grey primer condition.

Windscreen, [chummy] repaired, glazed and painted black c/w pillars.

Petrol tank, [chummy] repaired and painted black.

Wheels 19", [four] painted black fitted with new Avon tyres.

Axle, front, reconditioned with new King pins etc, painted black.

Seats, [chummy] a reproduction pair, grey primer.

Instrument set ie, PA speedo, switch panel, oil button and patent plate. Will separate if required.

Steering column, reconditioned.

Steering wheel, in fine condition.

Engine, 1930 c/w new crankshaft, dismantled.

Wayne Styles. 0417 532 412.



My name is Lachlan Story, a member from Bruny Island Tasmania. I have just purchased my 3rd Austin 7, a Supercharged Ulster replica

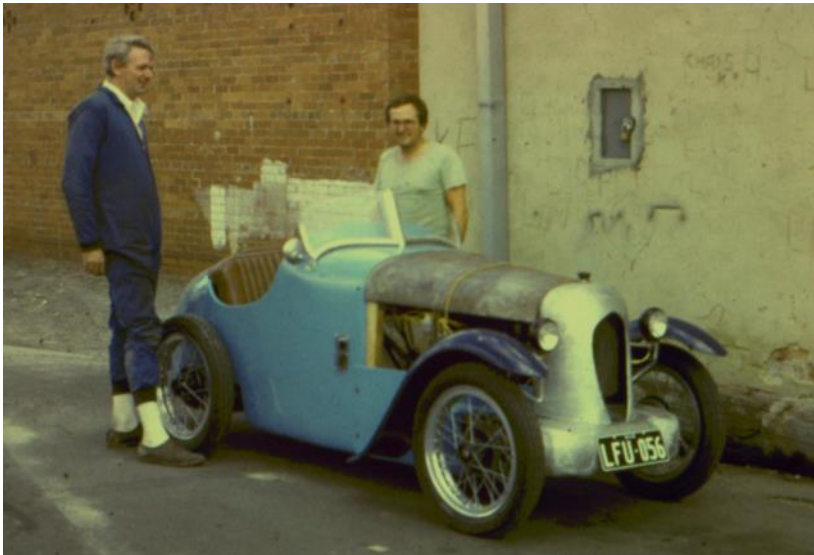

A blast from the past - the nearly completed Meteor built by John Bowring for Graeme Steinfort. A combination of a fibreglass tub, steel bonnet and alloy radiator cowl. Note the rear mudguards have yet to be fitted. Is it still in the Club?

Tony Johns

47th HISTORIC WINTON[®]

25th and 26th May 2024



www.historicwinton.org

Winton Motor Raceway, Benalla, Victoria

