

# SIDE LIGHTS

**FOUNDED 1969**  
**MORNINGTON PENINSULA HISTORICAL VEHICLES CLUB Inc.**  
**- A0001922T (MPHVC)**  
**Member of the Federation of Vintage, Veteran & Classic Vehicles Clubs and  
the Association of Motoring Clubs.**

## MAY 2023



***What a perfect venue for a car show!  
The National Steam Centre offers all visitors a wide variety  
of things to explore. From Thomas style model railway rides,  
to an animal farm, working steam displays, food stalls, trade  
stalls, car display and the most interesting collective display  
of vintage machinery in the numerous sheds.***

## UP COMING CLUB EVENTS

### MAY

- \* Wednesday 3rd Midweek Social Picnic. Mt Martha. (see details back page)
- \* Sunday 7th Pelikan Societe Café Breakfast Run. 9.30am (see details back page)
- \* Sunday 14th General Meeting - **The Hastings Club, Hastings. 12 noon** (see details back page)
- \* Wednesday 17th Committee Meeting. (The Hastings Club, 7.30pm)
- \* Sunday 28th Last Sunday Short Run - **Devil Bend Picnic/BBQ Run** (details below)

### JUNE

- \* Sunday 4th Pelikan Societe Café Breakfast Run. 9.30am (see details back page)
- \* Wednesday 7th Midweek Social Picnic. Mt Martha. (see details back page)
- \* Sunday 11th General Meeting - **The Hastings Club, Hastings. 12 noon** (see details back page)
- \* Wednesday 14th Committee Meeting. (The Hastings Club, 7.30pm)
- \* Sunday 25th Last Sunday Short Run– **Open To Suggestions ..... ??** (details to follow)

*If for any reason we need to cancel a planned event, we will endeavour to email and text those members that have email and mobile numbers listed with the club. We will also put a post on Facebook re any updates or cancellations! Please feel free to ring a Committee Member if you need to ask a question.*

## EVENT DETAILS

**SAVE THE DATE- Sunday 28th May** - Devil Bend Picnic/BBQ Run. BYO lunch or sausage n bread, chair etc. (The BBQ's here ignite free of charge!) Graydens Road, Tuerong (Melway Map 152 J3). Easiest way from Baxter Tavern is to travel down Coolart Rd — turn right into Graydens Rd — where the bitumen sweeps right and becomes Lodgers Rd ... take the left dirt Rd which is still actually continuation of Graydens Rd. Entrance to Reserve is 200 metres on left. Head to BBQ closest to Comfort Station at far right of parking area.

## CLUB NEWSFLASH

### **Reminder - Annual Club Memberships Fee's due 30th June.**

- In last months Sidelights we included your Annual Membership renewal form.
- Please list all cars registered with MPHVC. We do NOT require cars listed with another club.
- Members who have not paid by 30th June 2023 will automatically become a non-financial Member.
- We are obligated to report non-financial members with club plates to Vic Roads within 7 days after 30th June (7th July) to meet our requirements of contract with Vic Roads to operate as a Car Club.
- If any members are unable to pay fees, please speak with a committee member in advance so we can organize to help with your individual situation.
- Payment of fees can be by cheque or bank transfer. (BSB details are on annual fee form) Cash can only be paid in person at a GM or directly in person to a Committee Member. As per Australia Post recommendations – **PLEASE – NO CASH IN THE MAIL !**
- Bank transfers must use Surname as a reference for identification. (Remember to still mail us the form. Also a copy of the ATM receipt or on-line receipt **MUST BE ATTACHED TO THIS FORM**).
- **Regardless of which payment method you choose, it is a legal requirement that we MUST have a completed membership form for our files to comply with our records for Vic Roads.**

- For the Winter months of May, June, July and August our monthly General Meetings will be held at The Hastings Club in Hastings on a Sunday lunch time. Due to daylight savings and the fact that many of our members do not like to drive late at night when it is dark and the weather cold, this will allow our meetings to be more inclusive of those members. Meeting commences 12noon. Members can stay for lunch after meeting. Please make a prior booking and state that you are with MPHVC so they sit us all on tables together. We will not be meeting and travelling from Baxter Tavern due to the late start. Members to make their own way there. Only Members in attendance will be entered into the lucky raffle to win prizes. We will have this run on the Sunday after what would have been the second Thursday of the month GM. July is the only exception as the room was not available on the Sunday we needed...so we will have the GM the Sunday before what would have been the Thursday GM date.

**so.... 14th May, 11th June, 9th July, 13th August.**

- Re General Meetings at Hastings Club ...Whilst the popularity of the "For Sale Table" has been a success, and bonus for sellers, we will have to cease having it over the next 4 months whilst at the Hastings Club. The size and volume of some items are probably not appropriate for us to be carrying through the venue and we feel they may object. We will commence this again in September at the Church Hall. If you have any items that you do wish to sell before September...(eg engine, wheels, gear box, tools, ..etc) ... send me a photo and I will include it in the Sidelights magazine.
- Don't forget to still bring along library books for the "Library exchange/giveaway Table" at the monthly GM.

## **FOR SALE**

**1932 Austin Seven Opal Tourer Sedan.**

**Currently on H Plates. \$18,000 ONO.**

Engine/chassis no. M162514

Has had engine re-built.

Car is in excellent condition and has been lovingly restored and preserved over the years.

*Car is located in Hastings Victoria.*

*Call MPHVC 0414455989 and we will put you in contact.*



My wife and I went into town to shop. When we came out, there was a cop writing out a parking ticket. We went up to him and I said, "Come on man, how about giving a senior citizen a break?" He just ignored us and continued writing the ticket.

I called him an "butthead." He glared at me and started writing another ticket for having worn-out tires.

So my wife called him a "jerk." He finished the second ticket and put it on the windshield with the first. Then he started writing more tickets.

This went on for about 20 minutes. The more we offended him, the more tickets he wrote. He finally finished, sneered at us and walked away. Just then our bus arrived, and we got on it and went home.

We try to have a little fun each day now that we're retired. It's so important at our age!! 😊

## **MALDON JUNE SWAP MEET**

**SUNDAY JUNE 11TH**

**WE DO NOT STOP FOR RAIN**

**GATES OPEN TO THE PUBLIC AT 7AM**

**No bookings required**

**Saturday setup**

**STALLS \$20 per 6x6 metre site**

**Admission \$5 Kids free**

**Maldon Racecourse Reserve**

**Cnr Bendigo Rd. & Lewis Rd. Maldon VIC.**

**All enquiries please TEXT Mark**

**Mobile 0414 244 842 TEXT is preferred**

# Cavalcade of Transport National Steam Centre

To celebrate National Motoring Heritage Day



## SUNDAY 21st MAY 2023

1200 Ferntree Gully Road, Scoresby

Entry from 10am for Display vehicles & 11am for spectators

*Veteran, Vintage, Classic, Historic and Collector Vehicles.*

- Display vehicle entry by gold coin donation
- Coffee cart
- Sausage sizzle, Lions Club of Wheelers Hill fundraiser
- Gold coin entry to the National Steam Museum
- Train rides

Promoted by the  
Association of  
Motoring Clubs



Enquiries: 9558 4829 [www.aomc.asn.au](http://www.aomc.asn.au) [fb.com/infoaomc](https://fb.com/infoaomc)

Western District Historic Vehicle Club Inc Presents

## GEELONG BAY CITY SWAP MEET

Sat 13th May 2023 gates open 7am



Geelong Showgrounds (Melways Ref 452 E10)

### Costs:

- \*Gate entry, Adult/Teenage \$10per person, Under 13 yr Free
- \*Outdoor site, \$20 per 10x6m site + gate entry costs per person (no booking required for outdoor sites)
- \*Limited indoor sites, Booking req, contact for details/availability
- \*Area for display and sale of special interest vehicles (\$20 per car and gate entry costs per person)
- \*Parking for Non sellers at Geelong racecourse, Breakwater Rd.
- \*No eftpos, please have correct money for site and gate entry.
- \* Geelong Mobile ATM Facilities on site

**Friday night:** Camp sites available for stallholders only.

Entry from 5pm, gates will close at 9pm sharp. (site + per person entry costs)

**Rules:** Strictly no animals allowed in showgrounds. No fires permitted in anyway. No unauthorised food/drink vendors. No riding of a bicycle, scooter, motorcycle or rec vehicle.

Disability scooter permitted but must not exceed 4kph.

**Updates:** Via, Geelong Bay City Swap Meet Facebook page

**Contact:** email: [secretary@wdhvcgeelong.com](mailto:secretary@wdhvcgeelong.com)

Ph: 0417 306 177 (no texts)

WDHVC PO Box 200 Newcomb Vic 3219



## WANTED TO BUY

### Ford 351

### Cleveland engine

Wanted for a 1970 Mach 1 Mustang that is currently undergoing a full restoration. Long motor 2v or 4v.

Justin 0409 933 773

Located Seaford. Vic.



## WANTED TO BUY

### 2 SPARK PLUG CATALOGUES

from any year

1X - PYROX

1X - FIRESTONE

Contact - Bernie Valentini - 0403 164 031



## Bendigo National Swap Meet

### Featuring:

- 4 Wheel Drive Display
- Barn Finds & Survivor Car Display
- Die-cast Models & Toys
- Over 1700 Sites

11<sup>th</sup> & 12<sup>th</sup> November 2023



### Entry Prices

Saturday Only \$15

Sunday Only \$5

Children 15 and under Free

(if accompanied by an adult)

### Gates Open to the Public

Saturday 6am

Sunday 7am

Sheds Open 7am



[www.bendigowap.com.au](http://www.bendigowap.com.au)

Site Bookings 0427 446 660

General Enquiries 0434 730 822

[info@bendigowap.com.au](mailto:info@bendigowap.com.au)



## KITE PICNIC DAY

We had our annual kite picnic day recently at the Hastings Foreshore park.

The weather was great with just enough wind to get the kites air born. Luckily the council had been to mow the knee high grass so that was very appreciated considering the state the park has been in for the last few months.

A picnic in the sunshine lasted until early afternoon, with members, families and grandchildren enjoying the day.



**46<sup>th</sup> HISTORIC WINTON**  
**27th and 28th May 2023**

[www.historicwinton.org](http://www.historicwinton.org)  
Winton Motor Raceway, Benalla, Victoria

BENALLA RURAL CITY | The Austin Seven CLUB | WINTON MOTOR RACEWAY

Austin Seven Club Inc. A000390N | Photos - G.Rosewarne and SDPics

Williamson

# TYRECO

Est 1963

## CAR & TRUCK CENTRE

46 Brunel Road, SEAFORD

Phone 9776 4455

[www.williamsontyreco.com.au](http://www.williamsontyreco.com.au)

• NEW & USED TYRES • ALL MAJOR BRANDS • WHEEL BALANCING • ONSITE TYRE REPAIR

## **SCORESBY STEAM CENTRE CAR SHOW**

Hosted by the Dandenong Valley Historical Car Club, the recent Scoresby Picnic Car Show was a great day that attracted many entrants and visitors. What a perfect venue for a car show! The National Steam Centre offered all visitors a wide variety of things to explore and were of interest to all ages. From Thomas style model railway rides, to animal farm, working steam displays, food stalls, trade stalls, and the most interesting collective display of vintage machinery in the numerous sheds.



The Melbourne Steam Traction Engine club was established over 50 years ago with the aim of preserving the last of the road steam vehicles. It quickly expanded its scope to include a wide range of vintage machinery. The club has about 160 members sharing a common interest in vintage machinery. Many of the items the club has preserved are too large to be collected by private



individuals or require too many resources, financially or physically. With team work, the club has been able to save them and present them to the public. Today the club's museum features examples of the mechanical heritage that brought in our farm land, powered industry, generated our electricity, propelled our ships, worked our mines, ran our farms and built our roads. There are no paid employees and the museum and all its projects are run using the talented volunteer labour of members.



We had perfect weather on the day, warm but slightly overcast ... that was perfect for setting up the picnic tables and chairs and relaxing. Some MPHVC members set off in convoy to drive from the Baxter Tavern, whilst others chose to go direct and meet there. We were surprised how quickly we got there with only the weekend traffic on the freeway and were again surprised to see Darren in his 1929 Dodge roll up the same time as a member that had travelled there in a new car!! (although they did take a wrong turn along the way...(name I will not mention!!)). Ray had arrived early, with the Dandenong Valley Club, to help set up... and set aside a parking area for MPHVC members to park together and display our club logo signage.





We had a most enjoyable day exploring the various machinery displays, riding the model railway, watching the working engine displays, browsing the cars on display and catching up with friends from other clubs. At one point we were concerned we had lost Graham Bedford ... so I rang his mobile...he was happily chuffing around on the model railway with all the parents and kids!! Sounded fun, so off went another few of us! Was a great way to view the entire property and see the lager machinery stored in the back paddocks.

Prizes and presentations were awarded on the day, and a car owned by MPHVC member Brian, took out trophy for Best Post Classic with his Leyland P76.

The originality of this car certainly caught the eye of judges! Just goes to show .... you don't have to have the car in the most pristine condition that has had the equivalent of the cost of a house poured into it..... but an interesting and original example of a car that evokes memories of that era, shows the history and life of the car and what the car was like back in it's heyday!

***Well done Brian!***



**FOLLOW AND SUBSCRIBE TO MARK BEHR'S YOUTUBE CHANNEL FOR INFORMATIVE VIDEOS OF THE SCORESBY STEAM CENTER CAR SHOW, AND MANY OTHER INTERESTING SEGMENTS.**

<https://youtu.be/Tw9txlpUb1c>



## **PELIKAN SOCIETE BREAKFAST RUN**

Looks like we are all trying to make the most of the summer weather before winter hits.

Last months breakfast run was perfect weather to get the cars out for a spin to Hastings foreshore.



We all enjoyed the outside dining area with the smells and ambience of the waterfront. Dawn picked up Les to join us and Wayne drove him home... he managed to squeeze him into the MG without too much pushing and shoving required! Lets hope we get another Sunday of warm weather for one more outside breakfast!

## **MORNINGTON PENINSULA HISTORICAL VEHICLES CLUB Minutes of GM 13th April 2023. St Francis Xavier Hall, Frankston.**

**Meeting commenced:** 8.07 pm.

**Chair:** Ray Griffin, Vice President.

**Minute taker:** Peter Anscombe.

**Attendance:** As per Attendance record.

**Apologies:** Chris and Noelene Warwick and as per Attendance record.

**Visitor/New Member Welcome:** Nil.

**Minutes of General meeting 9/3/23:** No matters arising - Confirmed. Mark Behr, Eddie Reynolds

**Secretary's Report:** Usual renewals, statements etc.

**Treasurer's Report:** Nil.

**Editor's Report:** Mainly usual club and AOMC newsletters little other activity.

**Membership Report:** John Schipper advised 107 current members and 7 enquiries.

**Past Events:** Scoresby run enjoyable.

**Future Events:** Per Sidelights, in particular Cherry Farm Trivia Event Picnic 30th April.

**Federation Report:** Nil.

**AOMC Report:** Peter Anscombe elaborated on AOMC items forwarded to our members via email and in particular the responding to and elaborating on some of the issues covered in the minutes of the last AOMC delegates meeting.

**Club Permit Report:** Nil.

**General Business:**

**-Future meetings:** As previously agreed, the Club will be going into "winter meeting" mode, with May, Jun, July meetings being held at the Hastings Club on a Sunday (date TBA) at 12 noon. Lunch optional afterwards but you will need to book directly with the Hastings Club. Check with sidelights for details.

**-Membership Fees:** Ray mentioned that members need to make sure their fees are paid on time particularly if they have a vehicle on club permit.

**-Other Business:**

-Several members mentioned that they had cars for sale or were about to be put up for sale so keep an eye out in Sidelights.

-Several other non-club local items were mentioned, in particular Dawn referred to a newspaper article about a generous (\$100K) donation to the McClelland Gallery from the estate of former member Eric Belcher (decd). Eric was well known for dedication and involvement with our Club.

-AOMC - Mark Behr referred to recent communications from the AOMC and expressed some wonderment as to the issues referred to as future items for joint discussion with other bodies. He was concerned as to the general direction of the AOMC as an organisation representing the older car movement.

**-Memorabilia:** Colin Gardner advised that new items were being sourced and orders would be placed when members order and pay for items.

**-Chocolates:** Eddie Reynolds promoted the fund-raising chocolate offerings.

**-Raffle:** To close the meeting, Ray drew the raffle. The winners were birthday boy Wreford Cleeve and Peter Anscombe.

**-Items for Sale by Members.** Various items available.

**Meeting closed:** 8.47 pm.



# CAR CARE CORNER

By **Bernie Valentini** — (VACC Certified SMM)

Hi all Members, Friends and other interested Clubs. Welcome!

**AIR CONDITIONING:** A vital piece of Kit all year round as it not only keeps you cool on hot/warm days but is a boon to safety on wet cold days when your screen dangerously fogs up. You can still have your heater on full blast as well as the AC simultaneously so you don't freeze!

**1/.** The most common overlooked preventative maintenance item in the AC System is accumulation of debris in the gap between the Engine's Radiator and the Condenser (looks like another radiator usually in front near grille and parallel to Engine Radiator, which is not shown in this Schematic. Use a vacuum cleaner with home made extension made of thick cardboard or other and ensure you DONT scrape the honeycomb matrix in a rough manner lest you cause a leak.

**2/.** Keeping this area and also front and Rear in pristine condition ensures efficiency for both Engine Cooling and Passenger Comfort 24/7.

**3/.** Next easy check is ALL Drive Belts to ensure they're not loose, regardless of what their job is. Too tight will end in tears too. If your car is a modern with Serpentine Belt which looks like an old School Liquorice Strap and usually drives ALL accessories as it "serpentine" it's way around many pulleys and is too loose, then your Automatic Adjuster MUST be replaced IMMEDIATELY. I've seen totally preventable thousands of dollars damage caused by a derailed or broken Serpentine Belt. They never fail overnight. It takes months of neglect and lack of basic checks ANYONE can do: You don't have to know anything about cars for what I've written here today .

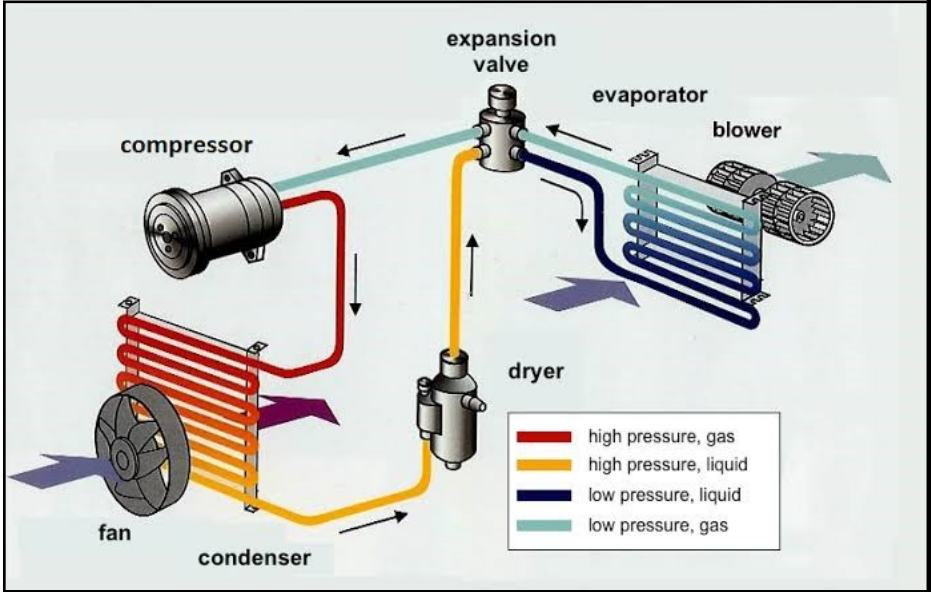

**4/.** So many things, along with the AC, in any car, can be affected by a loose Battery and loose Terminals. By law and for your benefit/safety, your Battery must be held fixed so it cannot move whatsoever. This also applies to the Battery Terminals.

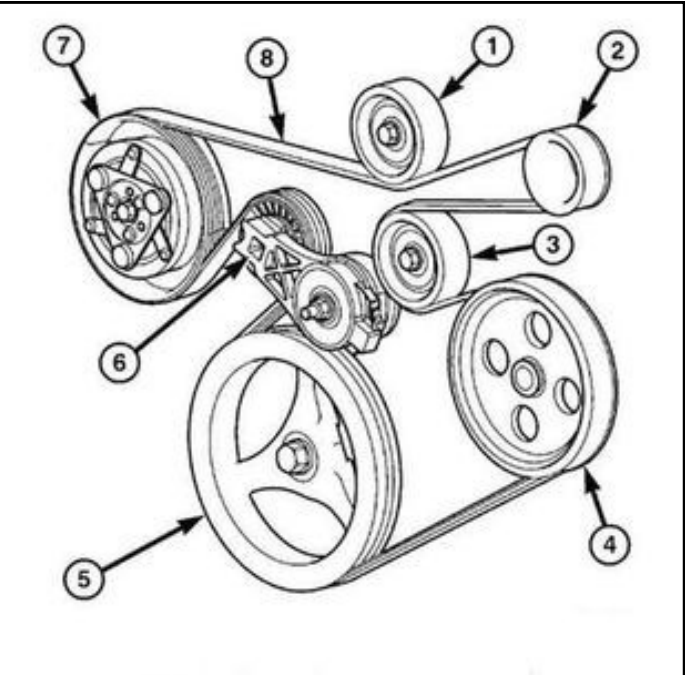

- 1 - IDLER PULLEY
- 2 - GENERATOR PULLEY
- 3 - IDLER PULLEY
- 4 - POWER STEERING PUMP PULLEY
- 5 - CRANKSHAFT PULLEY
- 6 - TENSIONER
- 7 - A/C COMPRESSOR PULLEY
- 8 - ACCESSORY DRIVE BELT

**5/.** Don't let stuff accumulate on your Dash and then wonder why your Demisters don't clear your screen!!!

**6/.** With engine running and AC on maximum and hand-brake on and Tranny in Park, open bonnet and visually check BOTH Electric Fans are spinning furiously. Regardless of any temperature on even the coldest day! If none or just one is working while AC is on then this is serious and must be addressed IMMEDIATELY. Ignoring this can destroy/overheat your very expensive engine and AC. It's asking for trouble to ignore serious issues. You will be obliged I guarantee it!

**7/.** Your Automatic Tensioner, which cannot be repaired and must be replaced at the first sign of misbehavior: Looseness, noisy operation, binding, any cracks or physical damage, or any signs of mis-alignment. The integrity of this device is of paramount importance.

If you have any doubts about anything, feel free to call me for free advice before you make it go POOF or BANG! My phone number is on rear of every Sidelights Monthly magazine in hard copy or at the end of this Monthly if it's email. Call ONLY between 10 am to 6 pm 7 days. Happy to chat!

**Bernie Valentini** ..... (Certified VACC SMM & VicRoads Vehicle Examiner)



“NO ONE KNOWS YOUR  
PASSION LIKE SHANNONS.”



Shannons Home and Comprehensive Car and Bike insurance is for motoring enthusiasts just like you, with features like:

- Choice of repairer ■ Agreed value ■ Multi-Vehicle & Multi-Policy discounts
- Limited Use & Club Plate cover ■ Laid up cover ■ One excess free windscreen claim per year
- Total loss salvage options ■ Home & Contents Insurance including \$10,000 enthusiast items cover for your collectables & tools
- Towing & storage costs as a result of loss or damage ■ Pay by the month premiums at no extra cost

Call Shannons on **13 46 46** for a quote on your special car, daily drive, bike or your home, and speak with a genuine enthusiast.



**SHARE THE PASSION**



Join the Shannons Club today! Get connected and share your passion - [shannons.com.au/club](http://shannons.com.au/club)

**INSURANCE FOR MOTORING ENTHUSIASTS | CALL 13 46 46 FOR A QUOTE | SHANNONS.COM.AU**

Shannons Pty Limited ABN 91 099 692 636 is an authorised representative of AAI Limited ABN 48 005 297 807, the product issuer. Some benefits only apply to comprehensive vehicle cover. Shannons has not taken account of your objectives, financial situation or needs. Read the Product Disclosure Statement before buying this insurance, available at [shannons.com.au](http://shannons.com.au). The Target Market Determination is also available. Terms, conditions, limits and exclusions apply. The type of cover must be specified on your certificate of insurance. If you do not use your vehicle in accordance with the vehicle usage shown on your policy certificate you may not be covered in the event of a claim. Discounts do not apply to the optional Shannons Roadside Assist or CTP. SHFMA2101 17/9/21 A

# OUR CLUB

The Mornington Peninsula Historical Vehicles Club Incorporated was founded in 1969 as a Family Social Club, aimed at assisting in the preservation, restoration, use and maintenance of historic vehicles, stationary engines and other mechanical memorabilia more than 25 years old. Particular emphasis is on veteran, vintage and classic eras together with later vehicles of interest. The MPHVC will also endeavour to assist local non-profit clubs and organizations by participating in their events when invited. Please address any correspondence to:

**The Secretary**  
**MPHVC Inc.**  
**PO Box 7056**  
**Karingal Centre, Frankston 3199**

Club Email Address: [mphvc@live.com.au](mailto:mphvc@live.com.au)

## OFFICE BEARERS, COMMITTEE MEMBERS & DELEGATES 2020/2021

President: — Chris Warwick - 0417 016 251  
Vice President: — Ray Griffin - 0409 216 273  
Secretary: — Nyree Parker - 0401 806 448  
[mphvc@live.com.au](mailto:mphvc@live.com.au)  
Treasurer: — David Hunt / Graham Bedford, Assistant  
Sidelights Editor: — Dawn Etccl - 0414 455 989  
[mphvc.sidelights@yahoo.com.au](mailto:mphvc.sidelights@yahoo.com.au)  
Sidelights Publisher: — Noelene Warwick  
Activities Co-ordinator: — VACANT  
Membership Officer: — John Schipper - 0419 551 378  
General Committee: — Noelene Warwick  
— Wayne Etccl  
— Colin Gardner  
— Bernie Valentini - 0403 164 031  
Permit Registrar: — Darren Crerar  
Welfare Officer: — Lorraine Mayne - 0412 446 978  
Memorabilia Officer: — Colin Gardner - 0409 130 804  
Permit Officers: — Ray Griffin - 0409 216 273  
— Doreen Madeley - 0488 547 988  
— Nyree Parker - 0401 806 448  
— David Hunt - 0412 175 258  
Safety Officer: — Ray Griffin - 0409 216 273  
AOMC Delegate: — Peter Anscombe  
Federation Delegate: — Alan Saunders

**- Preferred method of Red Plate Permit renewal signatory authorization, is to be done at a monthly General Meeting. Alternatively, post to Club and include a stamped, self-addressed envelope.**  
**- New vehicles, to be submitted for registry with MPHVC, must be approved via Safety Officer.**

**MPHVC Inc. PO Box 7056,  
Karingal Centre, Frankston 3199**

Do you want to contact the Club by email ?

Our Club Email Address is:

[mphvc@live.com.au](mailto:mphvc@live.com.au)

### MPHVC FACEBOOK LINK

[https://www.facebook.com/MPHVC-Mornington-Peninsula-Historical-Vehicles-Club-2488596817927756/?view\\_public\\_for=2488596817927756](https://www.facebook.com/MPHVC-Mornington-Peninsula-Historical-Vehicles-Club-2488596817927756/?view_public_for=2488596817927756)

## MONTHLY GENERAL MEETING

**Meeting place:** St Francis Xavier Centre. (Hastings Club in Winter months. May To August. 12 noon.)

**Where:** Rear of St Francis Xavier Church, 60 Davey St Frankston. Car park off Baxter Street and Park Street. (wheelchair access)

(Hastings Club, 155 Marine Parade, Hastings. 12 pm. 59 791740)

**When:** 2<sup>nd</sup> Thursday of every month at 8.00pm.

Supper Roster rotates supper duties amongst Club Members. (see Sidelights Calendar for members on Supper Roster).

(on the Sunday after what would have been the Thursday GM)

**Duties are as follows: (at church hall only)**

- First named Member buys 2x1 litre milks (reimbursed by Club).
- Set up tables, urn, cups and make tea and coffee.
- Wash up and stow everything away after supper is finished.
- Check tea, coffee and sugar supplies. If insufficient, please advise next month's rostered Members.
- Put Roster book on table at door.

*All Members - Please remember to bring a plate to share.*

## MONTHLY CLUB RUNS

### FIRST SUNDAY OF THE MONTH

#### Breakfast Run.

Meeting 9.30am at Pelikan Societe Café. Located next to the Hastings pier. 2 Marine Parade, Hastings. Full breakfast, toasted sandwiches or just coffee and muffins etc available. Indoor or outdoor seating available to choose from depending on seasons.

### FIRST WEDNESDAY OF THE MONTH

#### Midweek Social Picnic.

Social Meeting at 11.30 am. Balcombe Creek Estuary picnic area, near the rotunda. Mirang Avenue, Mount Martha. BYO chairs and refreshments.

### SUNDAY AFTER GENERAL MEETING

#### Mid Month Occasional Sunday Run.

Sunday after GM. An occasional organized run that is decided according to seasons and destination planning. Watch Sidelights magazine for if we have a run planned.

### LAST SUNDAY OF THE MONTH

#### End Of Month Short Sunday Run.

Meet prior to 10am Baxter Tavern, depart 10am. Destination planned on the day amongst those members that are present, or prior as printed in Sidelights. BYO refreshments and chair. Alternatively we may end up at a café. Weather and numbers present on day will help decide where we end up! Members encouraged to suggest destinations for future months.

## CLUB MAGAZINE "SIDELIGHTS"

Help to make Sidelights a success by contributing material you consider will be of interest to fellow Club Members.

The deadline for material to appear in the next issue of Sidelights is the 20<sup>th</sup> of each month. Where possible e-mail material to the Editor at [mphvc.sidelights@yahoo.com.au](mailto:mphvc.sidelights@yahoo.com.au)

Email photographs in 'jpeg' format to the Editor's email address above. All original material submitted will be returned.

#### DISCLAIMER -

*The information contained in this Newsletter is for general information purposes only. The MPHVC Club assumes no responsibility for errors, omissions or accuracy of advice published in the Newsletter.*